

Physics 2112
Physics for Scientists & Engineers
II
(Electromagnetism & Optics)

Dr. David Fazzini

Topics for Today

- Electric Force
- Electric Charge
- Coulomb's Law
- Electric Field

The Fundamental Forces

- Nuclear Strong: (Relative strength: 1)
- Electromagnetic: (Relative strength: 10^{-2})
- Nuclear Weak (Relative strength: 10^{-7})
- Gravitational (Relative strength: 10^{-38})

Try these (in low humidity)...

- Rub a balloon on your hair then let it stick to the wall.
- Quickly pull a piece of clear tape or plastic wrap off the roller. What do you observe?
- Run a comb through your hair then bring the comb near some small bits of paper. What happens?

We can now **define** the rubbing process as “**charging**” the objects. But is actually happening?

What is *Electric Charge*?

For lack of a better description, electric **charge is a property of matter** that produces an *electromagnetic field*. This field transmits the influence from one charge to another.

The basic question that any theory of electromagnetism tries to answer is...

“If I take some electric charges over here (let’s call them the *source charges*) and maybe jiggle them around, what happens to the other electric charges (that we’ll call the *test charges*), over there?” (-D. Griffiths)

Consider these observations:

- How do the two glass rods (rubbed with paper) behave when brought near each other?
- How do the two PVC rods (rubbed with paper) behave when brought near each other?
- How do the glass rod and rubber rod (each rubbed with paper) behave when brought near each other?
- How does a glass rod (rubbed with paper) behave when brought near a neutral object?
- How does a PVC rod (rubbed with paper) behave when brought near a neutral object?

Conclusions thus far...

- Rubbing causes some objects to become “charged.”
- A charged object attracts a neutral object. (This is the “test” for charge.)
- Charge can be transferred by contact.
- There are at least two different kinds of charge. (“Like” charge repels and “opposite” charge attracts.)

Questions:

- 1) If handed an object how could you determine if the object was “neutral,” “positive,” or “negative?”
- 2) Suppose there is a third type of charge. How could you reveal that an object had this type of charge?

Properties of Electric Charge

- Charge comes in **two forms** (“+” and “-”).
- “Likes” repel and “opposites” attract.
(This is the *electric force*.)
- Charge is **conserved**.
(Net charge cannot be created or destroyed.)
- Charge is **quantized**: $Q = Ne$,
where $N = \text{integer}$ and $e = 1.602 \times 10^{-19} \text{ C}$.

Conductors vs. Insulators

Conductors (e.g., metals, tap water...) are materials in which **electric charges move easily**.

Insulators (e.g., rubber, glass, plastic...) are materials in which **electric charges cannot move freely**.

Do not confuse *charge* with the *motion of charge*.

Question:

(1) Two identical metal spheres (A and B) on plastic stands are initially touching. (2) A glass rod rubbed with paper is brought near (but not touching) the left side of Sphere A. (3) While the rod is held close the spheres are separated. (4) The rod is then taken away. Describe the state of each sphere.

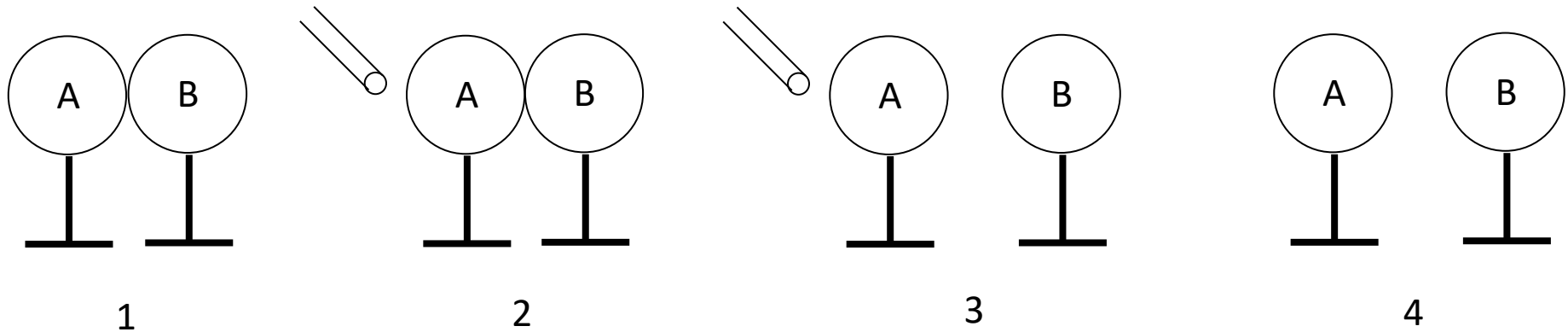

Coulomb's Law...

...describes the relationship between the electrostatic force and the charged particles.

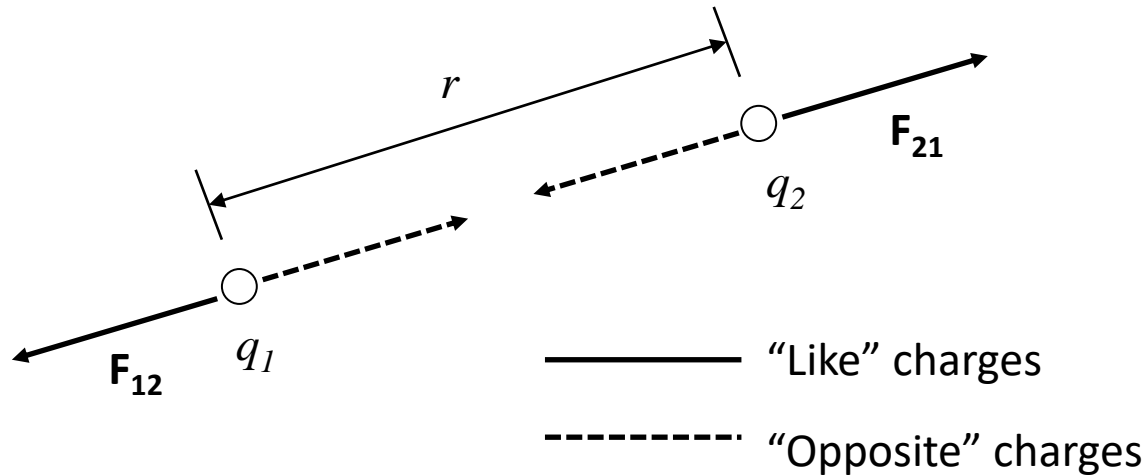

$$|\vec{F}_{12}| = |\vec{F}_{21}| \propto \frac{|q_1||q_2|}{r^2}$$

Coulomb's Law...

$$|\vec{F}_{12}| = |\vec{F}_{21}| = \frac{k|q_1||q_2|}{r^2}$$

where k = “the electrostatic constant”

$$k = \frac{1}{4\pi\epsilon_0} = 8.99 \times 10^9 \frac{\text{Nm}^2}{\text{C}^2}$$

and ϵ_0 = “the permittivity of free space”

$$\epsilon_0 = 8.85 \times 10^{-12} \frac{\text{C}^2}{\text{Nm}^2}$$

With regard to \mathbf{F}_{12} and \mathbf{F}_{21} :

- These forces are an “action-reaction” pair.
- These forces lie along the line joining the two charged objects.
- Coulomb’s law applies only to “point” charges.
- Electric forces obey the principle of superposition:

$$\vec{F}_1 = \vec{F}_{12} + \vec{F}_{13} + \vec{F}_{14} + \dots + \vec{F}_{1N} = \sum_{i=2}^N \vec{F}_{1i}$$

Units

The **SI unit for charge** is the **coulomb** (abbr. **C**).

Due to measurement accuracy reasons, the coulomb is a derived unit based on the **SI unit for current**: the **ampere** (abbr. **A**).

$$1 \text{ C} = (1 \text{ A})(1 \text{ s}). \text{ That is, } 1 \text{ A} = 1 \frac{\text{C}}{\text{s}}$$



With F in Newtons and r in meters,

$$k = \frac{1}{4\pi\epsilon_0} = 8.99 \times 10^9 \frac{\text{N m}^2}{\text{C}^2}, \text{ where}$$

$$\epsilon_0 = \text{permittivity of free space} = 8.85 \times 10^{-12} \frac{\text{C}^2}{\text{N m}^2}$$

Question

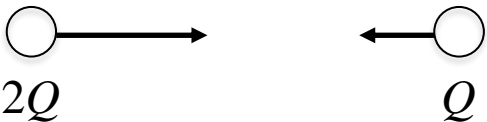
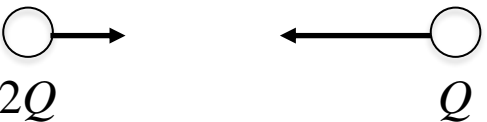
Two point charges have the charge shown. What do the relative electrical forces look like on the two charges?

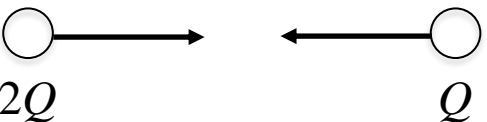
- A) 
- B) 
- C) 
- D) 

E) None of these.

Examples...

Consider three point charges that sit on the corners of a square. $|q_A| = |q_B|$. Let “ F ” be the magnitude of the force between q_A and q_B . For the given situations, determine the magnitude and direction of the net force on q_B in terms of F .

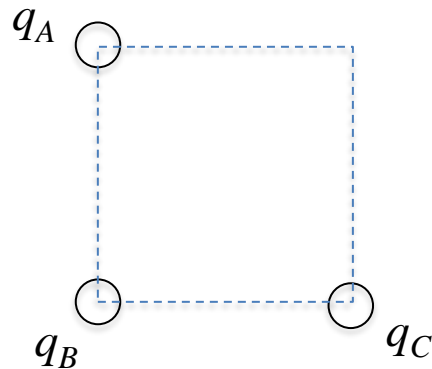

Question

Three charges $-q$, $+Q$, and $-Q$, are placed on the corners of an equilateral triangle as shown. The net force on $-q$ due to the other two charges is...

- a) vertically up.
- b) vertically down.
- c) zero.
- d) horizontal to the right.
- e) horizontal to the left.

